

Technical Specification:

Features:

- ◆ High power capability
- ◆ Economical
- ◆ Avalanche Voltage: 37V to 41V

Mechanical Data:

- ◆ Case: Copper case
- ◆ Epoxy: UL94-0 rate flame retardant
- ◆ Polarity: As marked of case bottom
- ◆ Technology vacuum soldered
- ◆ Lead: Plated lead, solderable per MIL-STD-202E method 208C
- ◆ Weight: 0.229 ounces 6.48 grams

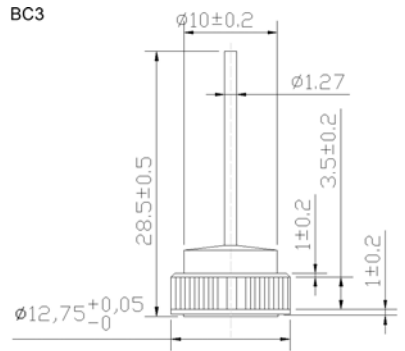

Dimensions in millimeters

Maximum Ratings and Electrical Characteristics

- ◆ Rating at 25°C ambient temperature unless otherwise specified.
- ◆ Single phase, half wave, 60Hz, resistive or inductive load.
- ◆ For capacitive load derate current by 20%.

Electrical Characteristics @ 25°C	Symbols	Min.	Nominal	Max.	Units
Peak repetitive reverse voltage	V_{RRM}		28		Volts
Working peak reverse voltage	V_{RWM}		28		
DC blocking voltage	V_{DC}		28		
Average rectified forward current at $T_c=125^\circ\text{C}$	I_o		40		Amps
Repetitive peak reverse surge current $T_c=10\text{msec}$ duty cycle <1%	I_{RSM}		40		Amps
Breakdown voltage (V_{br} @ $I_f=100\text{mA}$, $T_c=25^\circ\text{C}$) $I_f=90\text{Amps}$, $T_c=150^\circ\text{C}$, $PW=80\text{usec}$	V_{br1} V_{br2}	37	39	41 54	Volts
Forward voltage drop (V_{fwd}) @ $I_f=100\text{Amps}$ <300usec	V_f	0.98	1.05	1.08	Volts
Peak forward surge current	I_{FSM}		500		Ampes
Reverse leakage ($V_R=28\text{Vdc}$) $T_A=25^\circ\text{C}$	I_R	0.2	1.0	2.0	μA
Operating junction and storage temperature range	T_J, T_{STG}		-65 to +175		$^\circ\text{C}$

Notes: 1. Enough heatsink must be considered in application.

