

## Technical Specification:

### Features:

- ◆ High power capability
- ◆ Economical
- ◆ Avalanche Voltage: 24V to 32V

### Mechanical Data:

- ◆ Case: Copper case
- ◆ Epoxy: UL94-0 rate flame retardant
- ◆ Chip: Glass passivated chip or o.j chip
- ◆ Polarity: As marked of case bottom
- ◆ Technology vacuum soldered
- ◆ Lead: Plated lead, solderable per MIL-STD-202E method 208C
- ◆ Weight: 0.229 ounces 6.48 grams

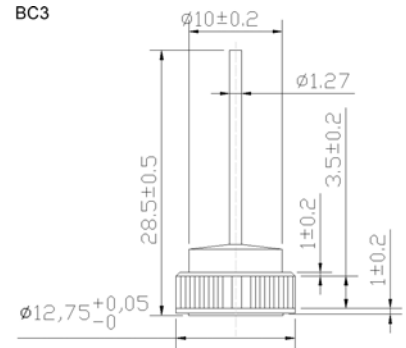

Dimensions in millimeters

## Maximum Ratings and Electrical Characteristics

- ◆ Rating at 25°C ambient temperature unless otherwise specified.
- ◆ Single phase, half wave, 60Hz, resistive or inductive load.
- ◆ For capacitive load derate current by 20%.

| Electrical Characteristics @ 25°C  | Symbols               | Min. | Nominal     | Max.     | Units            |
|--|-----------------------|------|-------------|----------|------------------|
| Peak repetitive reverse voltage  | $V_{RRM}$             |      | 20          |          | Volts            |
| Working peak reverse voltage   | $V_{RWM}$             |      | 20          |          |                  |
| DC blocking voltage  | $V_{RDC}$             |      | 20          |          |                  |
| Average rectified forward current at $T_c=125^\circ\text{C}$   | $I_T$                 |      | 50          |          | Amps             |
| Repetitive peak reverse surge current<br>$T_c=80\text{m sec duty cycle } <1\%$   | $I_{FSM}$             |      | 50          |          | Amps             |
| Breakdown voltage ( $V_{bi}$ @ $I_F=100\text{mA}$ , $T_c=25^\circ\text{C}$ )<br>$I_F=90\text{Amps}$ , $T_c=150^\circ\text{C}$ , $PW=80\text{usec}$ | $V_{bi}$<br>$V_{RSM}$ | 24   | 25/27       | 32<br>40 | Volts            |
| Forward voltage drop ( $V_{sd}$ ) @ $I_F=100\text{Amps}$ < 300usec   | $V_F$                 | 0.98 | 1.05        | 1.08     | Volts            |
| Peak forward surge current   | $I_{FSM}$             |      | 600         |          | Amps             |
| Reverse leakage ( $V_R=20\text{Vdc}$ ) $T_A=25^\circ\text{C}$  | $I_R$                 | 0.2  | 1.0         | 2.0      | $\mu\text{A}$    |
| Operating junction and storage temperature range   | $T_J, T_{STG}$        |      | -65 to +175 |          | $^\circ\text{C}$ |

Notes: 1. Enough heatsink must be considered in application.

