

## Technical Specification:

### Features:

- ◆ High power capability
- ◆ Economical
- ◆ Avalanche Voltage: 24V to 32V

### Mechanical Data:

- ◆ Case: Copper case
- ◆ Epoxy: UL94-0 rate flame retardant
- ◆ Polarity: As marked of case bottom
- ◆ Glass passivated chip
- ◆ Technology vacuum soldered
- ◆ Lead: Plated lead, solderable per MIL-STD-202E method 208C
- ◆ Mounting: Press Fit
- ◆ Weight: 0.21 ounces, 6.01 grams

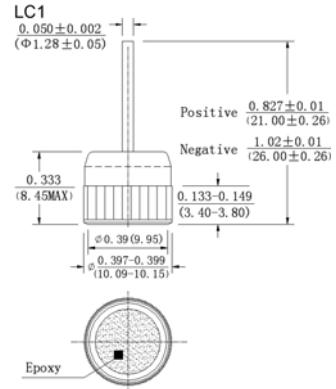

Dimensions in inches and (millimeters)

## Maximum Ratings and Electrical Characteristics

- ◆ Rating at 25°C ambient temperature unless otherwise specified.
- ◆ Single phase, half wave, 60Hz, resistive or inductive load.
- ◆ For capacitive load derate current by 20%.

Electrical Characteristics @ 25°C	Symbols	Min.	Nominal	Max.	Units
Peak repetitive reverse voltage	$V_{RRM}$		20		Volts
Working peak reverse voltage	$V_{RWM}$		20		
DC blocking voltage	$V_{DC}$		20		
Average rectified forward current at $T_c=125^\circ\text{C}$	$I_o$		30		Amps
Repetitive peak reverse surge current $T_c=10\text{msec}$ duty cycle <1%	$I_{RSM}$		30		Amps
Breakdown voltage ( $V_{br1}$ @ $I_f=100\text{mA}$ , $T_c=25^\circ\text{C}$ ) $I_f=90\text{Amps}$ , $T_c=150^\circ\text{C}$ , $PW=80\text{usec}$	$V_{br1}$ $V_{br2}$	24	25/27	32 40	Volts
Forward voltage drop ( $V_{fwd}$ ) @ $I_f=100\text{Amps}$ <300usec	$V_f$	0.98	1.05	1.08	Volts
Peak forward surge current	$I_{FSM}$		400		Amps
Reverse leakage ( $V_R=20\text{Vdc}$ ) $T_A=25^\circ\text{C}$	$I_R$	0.2	1.0	2.0	$\mu\text{A}$
Operating and storage junction temperature range	$T_J$ , $T_{STG}$		-65 to +175		$^\circ\text{C}$

**Notes:** 1. Enough heatsink must be considered in application.

